

**MY  
NEW F25.**

SPECIFICATION, OPTIONS.





2

THE ALTENDORF F 25:

## F 25 AN ALTENDORF FOR ALL.



*F 25 with optional extras*



## ALTENDORF – GLOBAL MARKET LEADER FOR PROFESSIONAL SLIDING TABLE SAWS.



*The height and tilt can be adjusted easily using two fold-out hand cranks.*



*Height and tilt displayed digitally on an LCD monitor.*



*Rip fence with precise manual adjustment.*

The Altendorf F 25 does everything a sliding table saw needs to do in very little space – all with characteristic Altendorf quality. Whether it's in your first own workshop, for everyday use in industrial manufacturing or as a high-performance second machine – the F 25 does it all while saving space, making it all the more productive. Materials such as wood-board materials, solid wood, wood-like materials or extruded profiles can be easily processed thanks to the best precision, simple handling and excellent cutting quality. The saw aggregate, which can be tilted on one side, also makes angular cuts possible. The smooth-running sliding table is based on the Altendorf system and like the digital height and tilt display, is part of the standard design. A machine for beginners and pros alike.



## PRECISION AND SAFETY FOR ALL.



*The crosscut-mitre fence simplifies crosscuts and mitre cuts because it does both.*

*Non CE Version: Optional*



*Occupational health and safety is very important to Altendorf. That's why we offer two systems for covering and extracting the saw blade. There is a small safety hood on the riving knife as standard, which allows a clear view of the cutting process thanks to its compact size. An optional large hood is also available, which adjusts to any material thickness and is self-locking.*



*LED illumination near the scorer unit provides more safety for work with the scorer.*



*Increase your productivity in a way that perfectly suits you with these additional equipment options: You can choose from many different optional extras to adjust your Altendorf F 25 to your personal requirements. The front support roller option helps the workpiece when trimming or for longitudinal cutting.*

*The F 25's extremely torsion-resistant machine frame is the basis for accurately repeatable, high-quality work on the sliding table saw. The precise tilting of the saw unit is guaranteed for life by large segments. The sliding table is intercepted by another stop at the cutting line. This is the only way to achieve a perfect cut.*





# YOUR F 25: IT NEEDS THIS MUCH SPACE.

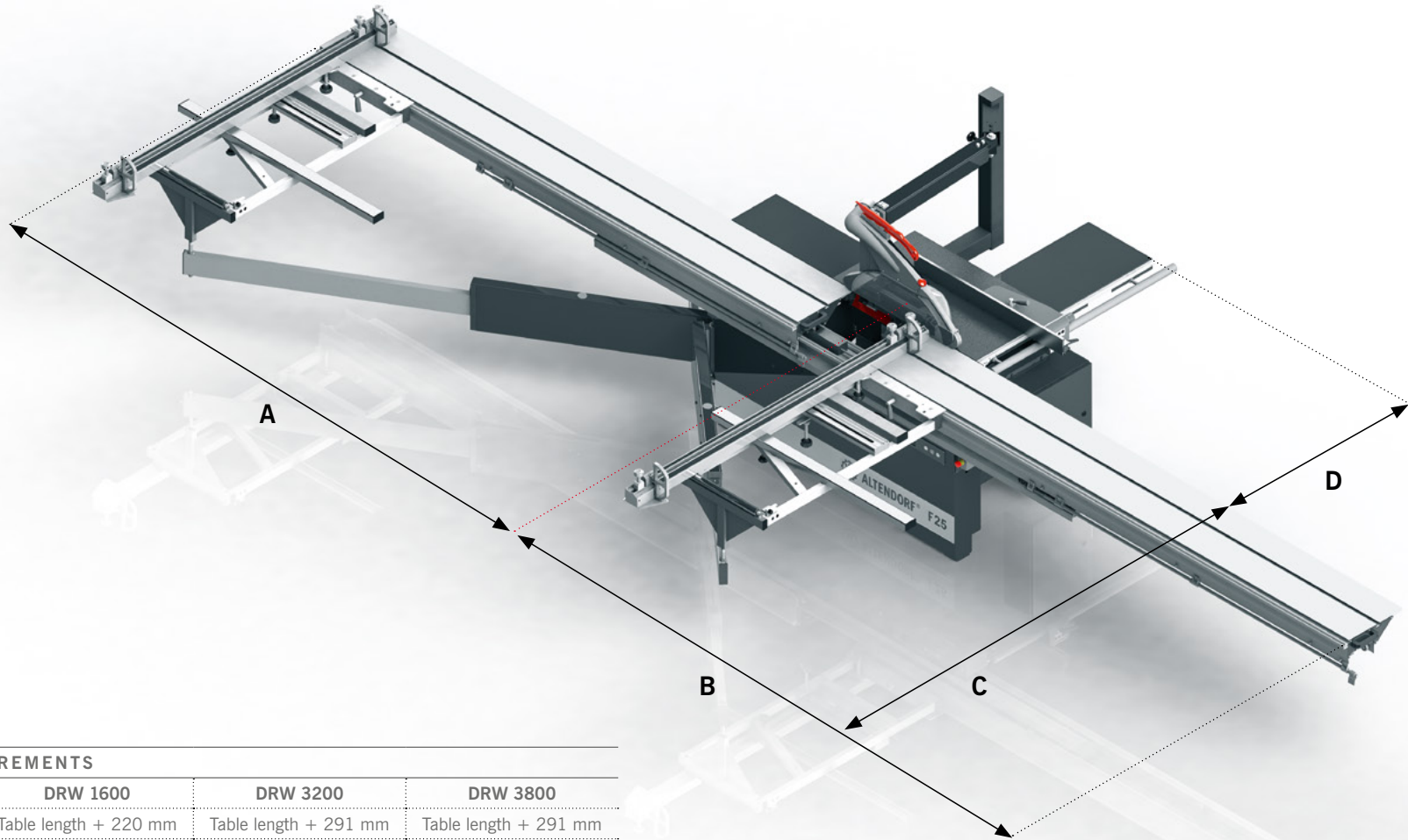

SPACE REQUIREMENTS			
	DRW 1600	DRW 3200	DRW 3800
A	Table length + 220 mm	Table length + 291 mm	Table length + 291 mm
B	Table length + 220 mm	Table length + 223 mm	Table length + 223 mm
Total length	3,640 mm	6,914 mm	8,114 mm
C	1,986 mm (maximum 3,576 mm)		
D	Cutting width + 305 mm		



**BASIC SPECIFICATION**

- Manual height and tilt adjustment of the saw blade from 0° to 46° with digital display
- Motor rating 4 kW (5.5 HP), 4,200 rpm
- Sliding table, table length 3,200 mm
- Rip fence including precise adjustment, cutting width 1,000 mm
- Crosscut-mitre fence, stops to 3,450 mm
- Preparation for the retrofit of a scoring unit
- Maximum saw blade diameter 315 mm, maximum saw blade projection 104 mm
- Non CE Version: saw blade diameter max. 350 mm,  
saw blade projection max. 121.5 mm
- Cutting height 100 mm, 70 mm at 45°
- Working height 91 mm

**OPTIONAL EQUIPMENT**

**Motor rating**

- 5.5 kW (7.5 HP), with three speeds

**Basic scorer**

- RAPIDO scoring system
- LED illumination in the hazard area around the scorer

**Sliding table**

- Table length 3,800 mm

**Rip fences**

- With precise adjustment, cutting width 1,410 mm
- With DIGIT X, cutting width 1,000 mm
- With DIGIT X, cutting width 1,410 mm

**Clipboard**

**Large extraction hood (PSV)**

**Front support roller**

**Manual clamp**

**Connection to dust extraction**

- Top connection: Ø = 50 mm
- PSV: Ø = 80 mm
- Bottom connection: Ø = 120 mm

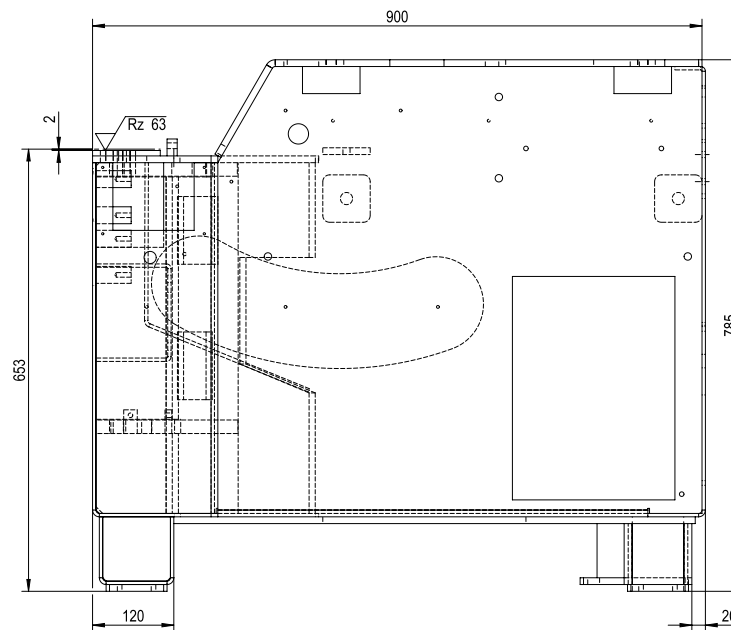
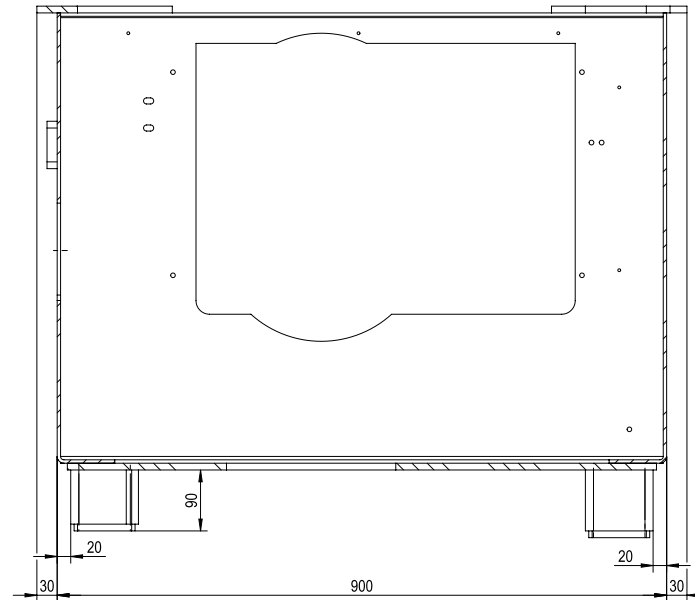

*These drawings show the clearance dimensions after maximum disassembly.*

