

Belfab

DUST COLLECTING EQUIPMENT
& DOWNDRAFT TABLES

A division of

 Pyradia



JNBM-OP SERIES

 Belfab

WOODWORKING DUST COLLECTOR

The **JNBM-OP** model is an industrial small capacity dust collector system generating up to 3500 CFM, available in single or three phases electrical connection. This collector is designed to collect dust particles ranging from coarse to mixed sizes, generated by wood machines operating in intermittent or continuous fashions and producing moderate to heavy dust loads. The JNBM-OP unit is generally recommended for applications involving one or two machines in a small shop environment or in larger facilities where there is a need for an industrial “stand alone solution”.



COMPACT DESIGN

At less than 11 feet high with a foot print less than 8 square feet. The compact design of the JNBM-OP makes it ideal for applications where space is a concern.

HIGH PERFORMANCE BLOWER

The JNBM-OP unit integrates a high performance industrial blower with top of the line filter bags offering an efficiency of 99.9982% at 2.5 micron. **Standard blowers** develop airflow capacities between 2,500 and 3,500 CFM. With their adjustable motor support and their universal housing, the Standard blowers can hold motors from 5 or 7.5 HP. A non-spark cast aluminum wheel comes as standard equipment on all standard blowers, giving you an AMCA type B construction.

*up to 5000 CFM for indoor installation. Above 5,000 CFM an outdoor set up is required (NFPA 664)



Belfab improves its products continuously and may change the specifications without notice.

DUST DISPOSAL OPTIONS

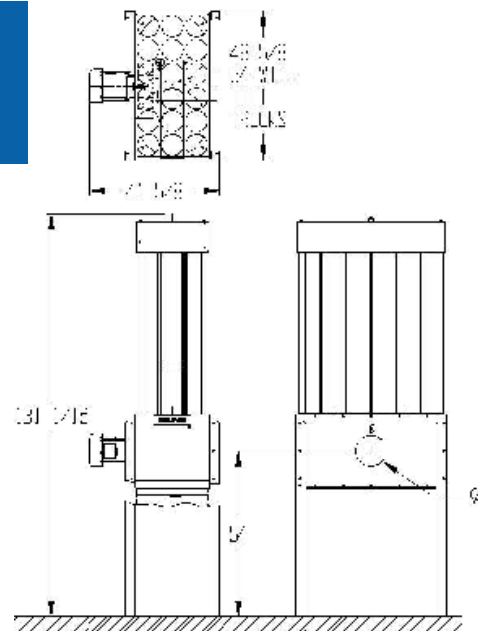

FEATURES

- Low maintenance direct drive centrifugal fan
- Premium TEFC motor
- High efficiency polytwill filter bags with efficiency level of 99.9982% (meets standard PM 2.5)
- The unit is configured for push application only
- CSAus approved
- A manual shaker per module
- 2 quick clamps per module
- 10 disposable plastic bags per module
- Compact configuration offering a small footprint
- Magnetic starter (as an option)

WARRANTY

- 12 month warranty

Capacity (CFM)	2 500	3 500
Blower Motor (HP)	5	7.5
Filtration surface (sq.ft)	165	
Dimensions (W x D X H) (in.)	44" x 48" x 130"	
Sound pressure (dB)	86	87
Inlet diameter (in.)	9	10
Disposal capacity ft ²	18	
Module weight (lbs)	325	

SAFETY STANDARDS AND REGULATIONS: Belfab's enclosureless dust collectors comply with NFPA 664 and 654 which permit inside installation of adequately designed enclosureless wood dust collector systems that produce a maximum of 5000 CFM and to which no mechanically fed machines such as abrasive sanders and moulders are installed. Consult NFPA regulations for more details. Also, consult your local authorities to verify all governing codes and regulations that apply in your locality in regards to the use of enclosureless dust collectors. It is the buyer's responsibility to follow all applicable national, local codes and regulations for installation and system operation.

Belfab improves its products continuously and may change the specifications without notice.